

## FLEXURAL STRENGTH OF CONCRETE

### WHAT is flexural strength?

Flexural strength is an indirect measure of the tensile strength of concrete. It is a measure of the maximum stress on the tension face of an unreinforced concrete beam or slab at the point of failure in bending. It is measured by loading 150mm x 150-mm concrete beams with a span length at least three times the depth. Smaller beam specimens of cross-section of not less than 75mm x 75mm are also recognized as a standard size. The flexural strength is expressed as Modulus of Rupture (MR) in MPa and is determined by standard test methods CSA A23.2-8C (third-point loading).

The specimen size and type of loading does impact the measured flexural strength and comparisons or requirements should be based on the same beam size and loading configuration. Flexural strength is about 10 to 15 percent of compressive strength, depending on the mixture proportions and type, size and volume of coarse aggregate used. When MR is critical to design, the best estimate is established from laboratory tests for specific mixtures and materials used.

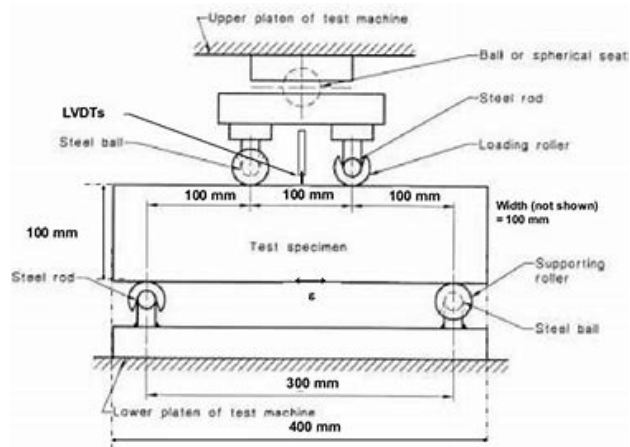

### WHY measure flexural strength?

Design of the thickness of concrete pavements are based on the flexural strength or MR. Factors include traffic loading and subgrade stiffness. Pavement designers often require validation that the proposed mixture will achieve the MR used in design. Concrete mixtures should be proportioned to achieve the MR as specified in contract documents. When acceptance in the field will be based on flexural strength tests, the concrete mixture should be appropriately designed to achieve a higher strength level that will reduce the risk of failing test results. Agencies that do not use MR for field control generally use compressive strength, as it is more convenient and reliable to judge the quality of concrete as delivered. A pre-established relationship between compressive and flexural strength may be developed for this purpose. Flexural strength testing is not used for structural concrete.

### HOW is flexural strength used?

Flexural strength is conservatively neglected in calculating the nominal flexural strength for design of structural members. The flexural strength, estimated from the empirical relationship, is used estimate the tensile stress that causes cracking of non-reinforced concrete and to evaluate deflections at service loads. Flexural strength tests are useful in research and laboratory evaluation of mixtures, but the sensitivity to testing variations does not lend itself to be used as a basis for acceptance or rejection of concrete in the field. Flexural strength tests for jobsite acceptance is commonly used for airfield pavements.

Beam specimens must be prepared in accordance with CSA A23.2-3C. Consolidate by rodding or vibration. Tap sides to close voids left by rodding without causing segregation. Follow the temperature and moisture retention requirements for laboratory and field curing outlined in CSA A23.2-3C and never allow the beam surfaces to dry at any time.

Specifications and investigation of apparent low strengths should take into account the higher variability of flexural strength testing. Standard deviation for concrete flexural strength tests from subsequent loads for projects with good control range from about 0.3 to 0.6 MPa. Standard deviation values exceeding 0.7 MPa may indicate problems with testing.

Where a correlation between flexural and compressive strength has been established, compressive strength of cores determined in accordance with CSA A23.2-14C can be used. Reduced strength measured on cores should be taken into account. Sawing beams for flexural strength tests will show a greatly reduced measured flexural strength and should not be done. Splitting tensile strength of cores by CSA A23.2-13C is sometimes used, but experience is limited.

Another procedure for in-place strength investigation uses compressive strength of cores calibrated by comparison with acceptable placements in proximity to the concrete in question:

### **WHAT are problems with flexural strength?**

Flexural tests are extremely sensitive to specimen preparation, handling, and curing procedures. Beam specimens are heavy and can be damaged during handling and transportation. Beams must be cured in a standard manner and tested while moist. A short period of drying can produce a sharp drop in flexural strength. Meeting all these requirements on a jobsite is extremely difficult and often result in unreliable and generally low MR test results.

The concrete industry and inspection and testing agencies are much more familiar with traditional cylinder compressive strength tests for control and acceptance of concrete. Flexural strength can be used for design, but the compressive strength established by a correlation with laboratory trial batches or empirical relationships should be for quality assurance and acceptance of concrete.

#### References:

1. CAN CSA A23.1-24/A23.2-24.
2. *Variation of Laboratory Concrete Flexural Strength Tests*, W. Charles Greer, Jr., ASTM Cement, Concrete and Aggregates, Winter, 1983, ASTM International, West Conshohocken, PA.
4. "Concrete Mixture Evaluation and Acceptance for Airfield Pavements" Meininger and Nelson, NRMCA Publication 178, September 1991, NRMCA, Alexandria, VA, [www.nrmca.org](http://www.nrmca.org).
5. *Compression vs. Flexural Strength for Quality Control of Pavements*, Kosmatka, CTT PL 854, 1985, Portland Cement Association, Skokie, IL, [www.cement.org](http://www.cement.org).
6. *Time to Rein in the Flexure Test*, Orrin Riley, *Concrete International*, August 1994, American Concrete Institute, Farmington Hills, MI, [www.concrete.org](http://www.concrete.org).
7. *Airport Paving Quality*, Gary Mass, *Concrete International*, Sept. 1997, pp. 46-53, American Concrete Institute, Farmington Hills, MI, [www.concrete.org](http://www.concrete.org). 1989, 2000, 2016
8. CIP 16, *Flexural Strength of Concrete*, National Ready Mix Concrete Association